

Motocompressori semi-ermetici
Semi-hermetic motor-compressors
Moto-compresseurs semi-hérmétiques
Halbhermetische Motorkompressoren

3rd Millennium Range / 2004



OFFICINE MARIO DORIN S.p.A.

Via Arellina, 388
50061 Compiobbi Firenze (Italy)
Tel. +39.055.62321.1
Fax +39.055.62321.380
Telex 570164 Dorin Firenze
<http://www.dorin.com>
E mail: dorin@dorin.com

DORIN



3rd Millennium Range

OMD: A future started in 1918

Founded in 1918 as a manufacturer of machine tools, air compressors, liquid pumps and as vehicle motor repairers, OMD started building compressors and refrigeration systems in 1932.

OMD has produced semi-hermetic compressors since 1957 and today they are the core business of the company. Today OMD are able to offer a vast range of over 70 semi-hermetic compressors ranging from 0.4hp to 150hp for both HFC and HCFC s to better meet the requirements of the market. To these are added a series of 2 stage compressors and a full range of accessories.

Efficiency, reliability and robustness are the principle characteristics of our compressors which are ready to face the stringent challenges and requirements of the new millennium.

Quality, Quality and Quality: this is Dorins' commitment.

Quality of suppliers

Quality of components: each single component is subjected to rigorous testing to ensure compliance with strict specifications.

Quality of Production: each production phase and each compressor is continuously monitored and tested to rigorous standards. The resulting data is archived and available at our clients disposal.

The various phases are followed and controlled in accordance with the Quality System ISO 9002-1994 certified by Lloyds Register Quality Assurance (Certificate No. LRC 170322).

All compressors are built and produced in accordance with the applicable European Norms: EN 292 - 1/2, EN 294, EN 60204, prEN 349, EN 60529, IEC 336-1, IEC 335-2-34.

The CE marking on each compressor plate and our Declarations of Conformity are testimony to our build quality.

Gamme du 3^{ème} millénaire

OMD: Un futur initié en 1918

Fondée en 1918, d'abord constructeur de machines outils, compresseurs à air, pompes de liquide et réparation de moteurs pour véhicules, l'entreprise OMD a initié en 1932 la production de compresseurs et produits de réfrigération.

Depuis 1957, l'entreprise OMD produit des compresseurs semi-hermétiques pour conditionnement d'air et réfrigération ce qui constitue aujourd'hui l'activité principale de la société.

L'entreprise OMD est aujourd'hui en mesure d'offrir une gamme complète et diversifiée de compresseurs semi-hermétiques pour mieux répondre aux demandes du marché: plus de 70 modèles aux puissances nominales de 0.4hp à 150hp étudiés et fabriqués pour pouvoir être utilisés avec les HCFC's ou les HFC's.

A ceci, s'ajoute une gamme de compresseurs à deux étages et un choix plus important d'accessoires.

Efficacité, fiabilité et robustesse: Ce sont les caractéristiques principales de nos compresseurs qui sont, bien sûr, prêts à affronter les défis du marché et continuer à être un point de référence même dans le nouveau millénaire.

Qualité, Qualité et Qualité: Voici le mot d'ordre de DORIN

Qualité des fournisseurs

Qualité de chaque composant: chaque composant fait l'objet de tests rigoureux pour en vérifier ses caractéristiques

Qualité du cycle productif: chaque phase de la production et chaque compresseur assemblé sont soumis à de rigoureux et continus contrôles et tous les résultats sont archivés et donc à disposition des clients.

Toutes les différentes phases sont exécutées et contrôlées en accord avec le Système de Qualité ISO9002-1994 certifié par Lloyd's Register Quality Assurance (Certificat N° LRC 170322).

Tous les compresseurs sont fabriqués et produits en accord avec les Directives Européennes applicables: EN 292 - 1/2, EN 294, EN 60204, prEN 349, EN 60529, IEC 336-1, IEC 335-2-34.

La marque CE estampillée sur la plaque de chaque compresseur et les déclarations en conformité en attestent.

3rd Millennium Range

OMD: Un futuro iniziato nel 1918

Fondate nel 1918 come costruttore di macchine utensili, compressori aria, pompe di liquido e riparazione di motori per autoveicoli, le OMD iniziarono nel 1932 a costruire compressori e impianti di refrigerazione.

È dal 1957 che le OMD producono compressori semiermetici per condizionamento e refrigerazione che oggi costituiscono il «core business» della Società.

Le OMD sono oggi in grado di offrire una gamma completa e diversificata di compressori semiermetici per meglio rispondere alle richieste del mercato: più di 70 modelli con potenze nominali da 0.4 hp a 150 hp progettati e costruiti per poter essere utilizzati conHCFC's o HFC's. A questo va aggiunta una gamma di compressori a doppio stadio e una serie molto ampia di accessori.

Efficienza, affidabilità e robustezza: sono queste le caratteristiche principali dei ns. compressori che sono sicuramente pronti a raccogliere le sfide del mercato e continuare ad essere un punto di riferimento anche nel nuovo millennio.

Qualità, Qualità e Qualità: ecco la parola d'ordine DORIN.

Qualità dei Fornitori

Qualità dei singoli componenti: ogni componente è soggetto a rigorosi tests per verificarne la rispondenza alle specifiche.

Qualità del ciclo produttivo: ogni fase della produzione ed ogni compressore assemblato è sottoposto a rigorosi e continui controlli e tutti i risultati sono archiviati e a disposizione dei Clienti.

Tutte le varie fasi sono eseguite e controllate in accordo al Sistema di Qualità ISO9002-1994 certificato dal Lloyd's Register Quality Assurance (Certificato n° LRC 170322).

Tutti i compressori sono costruiti e prodotti in accordo alle Direttive Europee applicabili: EN 292 - 1/2, EN 294, EN 60204, prEN 349, EN 60529, IEC 336-1, IEC 335-2-34.

Il marchio CE stampigliato sulla targhetta di ogni singolo compressore e le relative Dichiarazioni di Conformità ne attestano la rispondenza.

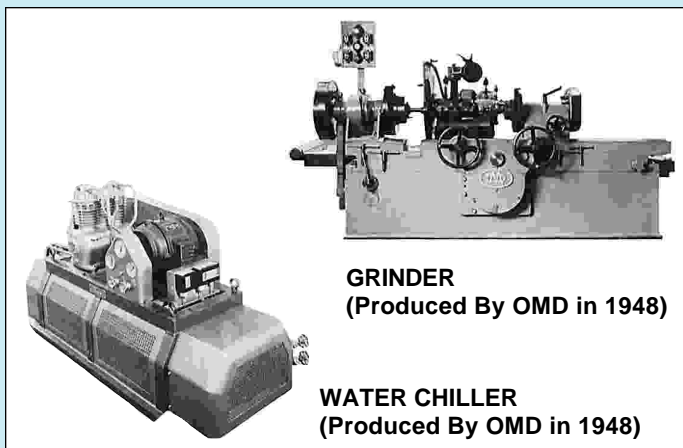

GRINDER
(Produced By OMD in 1948)

WATER CHILLER
(Produced By OMD in 1948)

3rd Millennium Range

OMD: Die Zukunft stammt aus dem Jahr 1918

Nach der Gründung im Jahr 1918 als Herstellungsbetrieb von Werkzeugmaschinen, Luftverdichtern, und Flüssigkeitspumpen sowie als Kfz-Reparaturwerkstatt begann man bei OMD im Jahr 1932 mit der Herstellung von Kompressoren und Kühlanlagen.

Seit 1957 produziert OMD nun halbhermetische Kompressoren für Klimaanlage und sonstige kältetechnische Anwendungen, die mittlerweile zum «Core Business» der Gesellschaft avanciert sind.

Heute kann das Haus OMD mit einer umfassenden und breit gefächerten Angebotspalette von halbhermetischen Kompressor aufwarten und die Anforderungen des Marktes somit bestens erfüllen: über 70 Modelle, deren Nennleistungen von 0,4 PS bis hin zu 150 PS reichen und speziell für den Einsatz von FCKW oder FKW konzipiert wurden.

Hinzu kommt eine gesonderte Produktpalette von zweistufigen Kompressoren sowie ein äußerst reichhaltiges Angebot an Zubehörteilen. Leistungsvermögen, Zuverlässigkeit und Robustheit: dies sind die hervorstechendsten

Eigenschaften unserer Kompressoren, mit denen wir von keiner Herausforderung des Marktes zurückschrecken und auch im dritten Jahrtausend eine feste Bezugsgröße sein werden.

Qualität, Qualität und wieder Qualität: dies ist das Motto des Hauses DORIN: Qualität der Lieferanten.

Qualität der einzelnen Bauteile: jedes Bauteil wird strengen Tests unterzogen, um seine Übereinstimmung mit den jeweiligen Spezifikationen zu überprüfen.

Qualität des Produktionsablaufs: jede Phase der Produktion und jeder zusammengebaute Kompressor werden ständigen, strikten Kontrollen unterzogen; alle Testergebnisse werden archiviert und stehen dem Kunden zur Verfügung.

Die Abwicklung und Kontrolle sämtlicher Herstellungsphasen erfolgt gemäß dem Qualitätssicherungssystem ISO 9002-1994 mit Zertifizierung beim Lloyd's Register Quality Assurance (Zertifikat Nr. LRC 170322)

Die Kompressoren werden ausnahmslos unter Einhaltung der anwendbaren Europäischen Richtlinien konstruiert und hergestellt: EN 292 - 1/2, EN 294, EN 60204, prEN 349, EN 60529, IEC 336-1, IEC 335-2-34.

Die auf dem Typenschild jedes einzelnen Kompressors befindliche CE-Kennzeichnung sowie die entsprechenden Konformitätserklärungen bestätigen die Einhaltung der genannten Normen.

Gamma Completa - Complete Range Gamme complete - Komplettserie

Modello Model Modele Modell	Volume spost. Displacem. Volume bal. m³/h	Campo appl. - Appl. range Champ. d'appl. - Anwend.			Serie Range Serie Reihe	Peso netto Net weight Poids net Nettogewicht Kg.	Teach Data see page
		R22 R407C	R404A R507	R134a			
K 750CC K 750CS K 1000CC	32,54 38,64 38,64	H M H	H M H	H H H	K4 K4 K4	113 113 118	da/from 12 a/to 27
KP 750CS KP1000CC	38,65 38,65	M H	M H	H H	KP KP	115 120	da/from 30 a/to 33
K 1000CS KP1000CS	48,80 48,80	M M	M M	H H	K4 KP	120 120	da/from 12 a/to 27 da/from 30 a/to 33
K 1500CC KP1500CC KP1500CS KP2000CC	48,82 48,82 56,95 56,95	H H M H	H H M H	H H H H	K4 KP KP KP	120 120 122 122	da/from 12 a/to 27 da/from 30 a/to 33
K 1500CS K 2000CC K 1500CB K 2500CC K 2500CB K 3000CC	57,90 57,90 73,20 73,20 83,90 83,90	M H M H L H	M H M H L H	H H H H H H	K5 K5 K5 K5 K5 K5	173 173 173 173 173 182	da/from 12 a/to 27
K 3000CS K 3500CC K 3000CB K 4000CC K 4500CS	110,6 110,6 126,7 126,7 138,3	M H L H M	M H L H M	H H H H H	K6 K6 K6 K6 K6	228 233 228 233 239	da/from 12 a/to 27
K 4700CS K 5000CC K 5500CC K 5000CS K 6000CC K 6000CS K 7500CC	153,7 153,7 169,1 184,4 184,4 199,8 199,8	M H H M H M H	M H H M H M H	H H H H H H H	K7 K7 K7 K7 K7 K7 K7	335 335 335 340 345 345 345	da/from 12 a/to 27
K 10000CC K 11000CC K 13000CC K 15000CC	249,82 299,79 349,75 399,72	H H H H	H H H H	H H H H	K8 K8 K8 K8	570 580 590 600	in pubblicazione not yet available

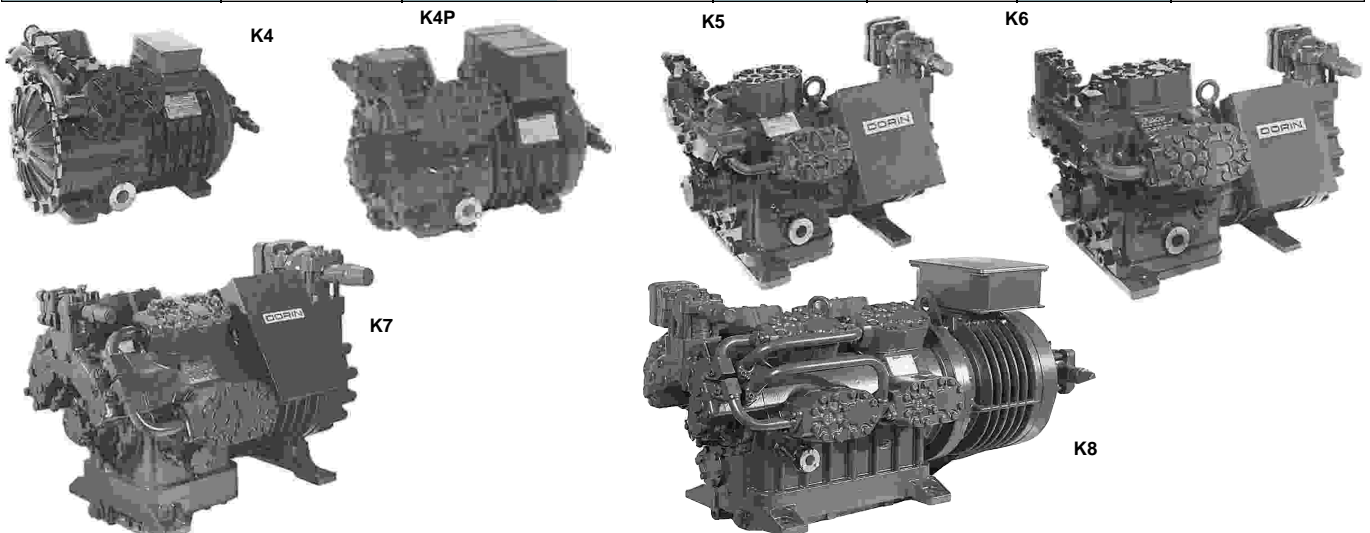

**CARATTERISTICHE TECNICHE
TECHNICAL CHARACTERISTICS
CARATTERISTIQUES TECHNIQUES
TECHNISCHE CHARAKTERISTIKEN**

**ACCESSORI
ACCESSOIRES
ACCESSOIRES
ZUBEHÖRTEILE**

Serie Range Serie Reihe	Modello Model Modelle Modell	Cilind. Cylind. Cylind. Zylind.	Volume spost. Displacem. Volume bal. m³/h		TE	DPS	INT 69	CPM	CH	CR	BF	WH	US	DTC	OP	OL
			n.	50 Hz												
H1	H 40 CS	2	2,89	3,47	★	○	○	○	○	○	○	○	○	○	○	○
	H 50 CS	2	3,86	4,63	★	○	○	○	○	○	○	○	○	○	○	○
	H 75 CC	2	3,86	4,63	★	○	○	○	○	○	○	○	○	○	○	○
	H 75 CS	2	5,30	6,36	★	○	○	○	○	○	○	○	○	○	○	○
	H 100 CC	2	5,30	6,36	★	○	○	○	○	○	○	○	○	○	○	○
	H 100 CS	2	6,75	8,10	★	○	○	○	○	○	○	○	○	○	○	○
	H 150 CC	2	6,75	8,10	★	○	○	○	○	○	○	○	○	○	○	○
	H 150 CS	2	7,71	9,25	★	○	○	○	○	○	○	○	○	○	○	○
	H 180 CC	2	7,71	9,25	★	○	○	○	○	○	○	○	○	○	○	○
	H 180 CS	2	8,47	10,16	★	○	○	○	○	○	○	○	○	○	○	○
	H 200 CC	2	8,47	10,16	★	○	○	○	○	○	○	○	○	○	○	○
	H 200 CS	2	9,88	11,86	★	○	○	○	○	○	○	○	○	○	○	○
	H 220 CC	2	9,88	11,86	★	○	○	○	○	○	○	○	○	○	○	○
	H 220 CS	2	10,85	13,02	★	○	○	○	○	○	○	○	○	○	○	○
H 250 CC	2	10,85	13,02	★	○	○	○	○	○	○	○	○	○	○	○	
H 250 CS	2	12,17	14,60	★	○	○	○	○	○	○	○	○	○	○	○	
H 280 CC	2	12,17	14,60	★	○	○	○	○	○	○	○	○	○	○	○	
H2	H 290 CS	2	14,74	17,69	★	○	○	○	○	○	○	○	○	○	○	○
	H 300 CC	2	14,74	17,69	★	○	○	○	○	○	○	○	○	○	○	○
	H 300 CS	2	15,94	19,13	★	○	○	○	○	○	○	○	○	○	○	○
	H 350 CC	2	15,94	19,13	★	○	○	○	○	○	○	○	○	○	○	○
	H 350 SB	2	17,53	21,04	★	○	○	○	○	○	○	○	○	○	○	○
	H 380 CC	2	17,53	21,04	★	○	○	○	○	○	○	○	○	○	○	○
	H 380 SB	2	19,53	23,44	★	○	○	○	○	○	○	○	○	○	○	○
	H 390 CS	2	19,53	23,44	★	○	○	○	○	○	○	○	○	○	○	○
	H 392 CS	2	23,31	27,97	★	○	○	○	○	○	○	○	○	○	○	○
K3	K 400 CC	2	16,76	20,11	★	○	○	○	○	○	○	○	○	+	○	○
	K 400 CS	2	19,30	23,16	★	○	○	○	○	○	○	○	○	+	○	○
	K 470 CC	2	19,30	23,16	★	○	○	○	○	○	○	○	○	+	○	○
	K 470 CS	2	23,37	28,04	★	○	○	○	○	○	○	○	○	+	○	○
	K 500 CC	2	23,37	28,04	★	○	○	○	○	○	○	○	○	+	○	○
	K 500 SB	2	26,50	31,80	★	○	○	○	○	○	○	○	○	+	○	○
	K 500 CS	2	26,50	31,80	★	○	○	○	○	○	○	○	○	+	○	○
K4	K 740 CC	2	26,50	31,80	★	○	○	○	○	○	○	○	○	+	○	○
	K 750 CC	4	32,54	39,05	★	○	○	○	○	○	○	○	○	+	○	○
	K 750 CS	4	38,64	46,37	★	○	○	○	○	○	○	○	○	+	○	○
	K 1000 CC	4	38,64	46,37	★	○	○	○	○	○	○	○	○	+	○	○
	K 1000 CS	4	48,80	58,56	★	○	○	○	○	○	○	○	○	+	○	○
K5	K 1500 CC	4	48,80	58,56	★	○	○	○	○	○	○	○	○	+	○	○
	K 1500 CS	6	57,90	69,48	★	○	★	○	○	○	○	○	○	+	○	○
	K 2000 CC	6	57,90	69,48	★	○	★	○	○	○	○	○	○	+	○	○
	K 1500 CB	6	73,20	87,84	★	○	★	○	○	○	○	○	○	+	○	○
	K 2500 CC	6	73,20	87,84	★	○	★	○	○	○	○	○	○	+	○	○
	K 2500 CB	6	83,90	100,68	★	○	★	○	○	○	○	○	○	+	○	○
K6	K 3000 CC	6	83,90	100,68	★	○	★	○	○	○	○	○	○	+	○	○
	K 3000 CS	6	110,6	132,72	★	○	★	○	○	○	○	○	○	+	○	○
	K 3500 CC	6	110,6	132,72	★	○	★	○	○	○	○	○	○	+	○	○
	K 3000 CB	6	126,7	152,04	★	○	★	○	○	○	○	○	○	+	○	○
	K 4000 CC	6	126,7	152,04	★	○	★	○	○	○	○	○	○	+	○	○
K7	K 4500 CS	6	138,3	165,96	★	○	★	○	○	○	○	○	○	+	○	○
	K 4700 CS	8	153,7	184,44	★	○	★	○	○	○	○	○	○	+	○	○
	K 5000 CC	8	153,7	184,44	★	○	★	○	○	○	○	○	○	+	○	○
	K 5500 CC	8	169,1	202,92	★	○	★	○	○	○	○	○	○	+	○	○
	K 5000 CS	8	184,4	221,26	★	○	★	○	○	○	○	○	○	+	○	○
	K 6000 CC	8	184,4	221,26	★	○	★	○	○	○	○	○	○	+	○	○
	K 6000 CS	8	199,8	239,76	★	○	★	○	○	○	○	○	○	+	○	○
K 7500 CC	8	199,8	239,76	★	○	★	○	○	○	○	○	○	+	○	○	

TE = Prot. a Termistori
Thermistor Prot.
Protect. par therm.
Thermistorenschutz

DPS = Sensore pressostato differenziale
Oil differential pressure sensor
Capteur de pression différentielle d'huile
Öldruck sensor

INT 69 = Mod. elettronico
Elect. module
Declencheur élect.
Auslösegerät

CPM = Modulo protezione compressore
Compressor protection module
Module de protection du compresseur
Kompressor schutzmodul

 CH = Resistenza carter
Crankcase Heater
Résistance carter
Ölsumpfheizung

 CR = Regolatore di potenza
Capacity control system
Régulateur de puissance
Leistungsregler

 BF = Ventilazione
raffreddamento
ausiliaria
Body cooling fan
Ventilation pour
refroidir auxiliaire
Zylinderkopfkühlung

 WH = Raffreddamento
della testata con acqua
Water cooled head
Tête refroidie à eau
Wasserkühlung des
Zylinderkopfes

 US = Partenza a vuoto
By-pass system
Démarrage à vide
Anlaufentlastung

 C = Iniezione di liquido
Liquid injection
Injection de liquid
Flüssigkeitseinspritzung

O.P. = Pressostato differenziale olio
Oil differ. press.switch
Pressostat différentiel huile
Öldruckschalter

 OL = Regolatore livello olio
Oil level Float valve
Régulateur de niveau
d'huile
Olstandsregelung

★ Accessori di normale fornitura
Standard supply
Accessoires livrés normalement
Zubehörteile für standard
Auslieferung

✚ Predisposto
Arranged
Predispose
Vorbereitet

INGOMBRI - OVERALL DIMENSIONS - ENCOMBREMENTS - ABMESSUNGEN

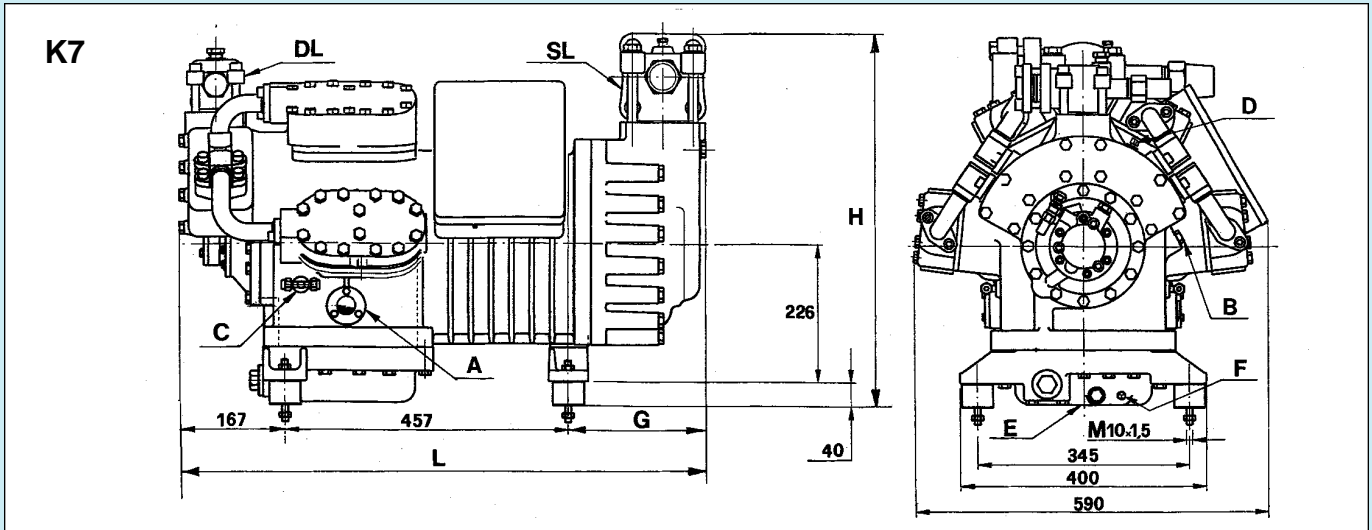

Modello Model Modele Modell	G	H	L	Rub. aspir. Suct.valve Vanne aspir. Sauventif SL	Rub. scarico Disc.valve Vanne refolement Druckventil DL	Carica olio Oil charge Charge Huile Öfüllung Kg.	Peso netto Netweight Poids net Nettogewicht Kg.
K 4700 CS	222	605	846	66s	42s	8.5	335
K 5000 CC	222	605	846	66s	42s	8.5	335
K 5500 CC	222	605	846	66s	42s	8.5	335
K 5000 CS	222	605	846	80s	42s	8.5	340
K 6000 CC	222	605	846	80s	42s	8.5	345
K 6000 CS	222	605	846	80s	42s	8.5	345
K 7500 CC	222	605	846	80s	42s	8.5	345

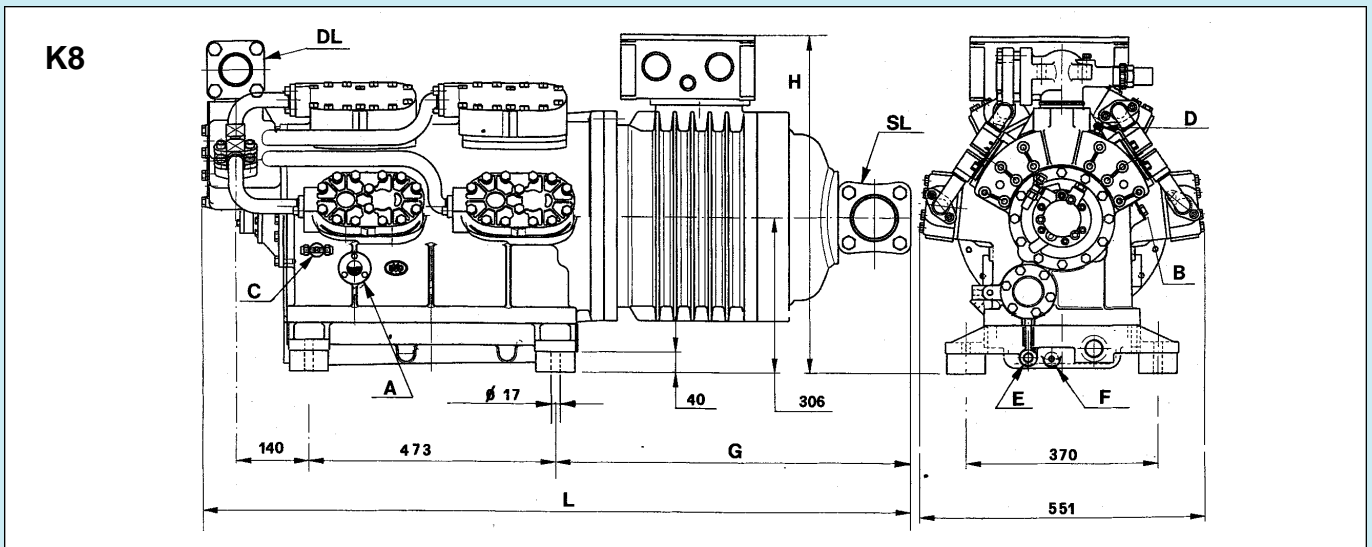

Modello Model Modele Modell	G	H	L	Rub. aspir. Suct.valve Vanne aspir. Sauventif SL	Rub. scarico Disc.valve Vanne refolement Druckventil DL	Carica olio Oil charge Charge Huile Öfüllung Kg.	Peso netto Netweight Poids net Nettogewicht Kg.
K 10000 CC	752	660	1365	80s	54s	21	570
K 11000 CC	752	660	1365	80s	54s	21	580
K 13000 CC	752	660	1365	80s	54s	21	590
K 15000 CC	752	660	1365	80s	54s	21	600

- | | | | |
|---------------------------|-------------------------|-------------------------|-----------------------|
| A Spia Olio | Oil Sight | Voyant d'huile | Oelschauglas |
| B Tappo carica Olio | Oil charge plug | Bouchon huile | Oelfuellschraube |
| C Presa Bassa Press. | Low pressure tap | Prise basse pression | Anschluss Niederdruck |
| D Presa Alta Press. | High pressure tap | Prise haute pression | Anschluss Hochdruck |
| E Tappo scarica olio | Oil drain plug | Bouchon de vid. d'huile | Oelablass Schraube |
| F Resistenza carter | Crankcase heater | Resistance carter | Oelsumpheizung |
| DL Rubinetto Compressione | Discharge service valve | Vanne de refolement | Druckabsperventil |
| SL Rubinetto Aspirazione | Suction service valve | Vanne aspiration | Saugabsperventil |



CAPACITÀ FRIGORIFERA
REFRIGERATING CAPACITY

PUISSANCE FRIGORIFIQUE
KÄLTELEISTUNG

R134a

Watt

Modello Model Modelle Modell	Temp. cond. Cond. temp. Temp. de cond. Kond. temp. °C	Temperature Evapor. - Evaporating temper. - temp. evapor. - Verdampfungstemp. °C							
		C				S			B
		+ 10	+ 5°	0°	-5°	* -10°	-15°	-20°	
K 750 CC	+ 35°	26731	22230	18178	14575	11419	8713	6455	
	+ 45°	23402	19290	15627	12413	9647	7329	5461	
K 750 CS	+ 35°	31998	26509	21596	17259	13499	10314	7706	
	+ 45°	27847	22895	18519	14719	11496	8848	6777	
K 1000 CC	+ 35°	31998	26509	21596	1725	13499	10314	7706	
	+ 45°	27847	22895	18519	14719	11496	8848	6777	
K 1000 CS	+ 35°	42124	35037	28678	23048	18146	13972	10527	
	+ 45°	36758	30401	24772	19872	15701	12257	9542	
K 1500 CC	+ 35°	42124	35037	28678	23048	18146	13972	10527	
	+ 45°	36758	30401	24772	19872	15701	12257	9542	
K 1500 CS	+ 35°	50325	42100	34697	28116	22356	17419	13304	
	+ 45°	43601	36234	29689	23965	19064	14985	11728	
K 2000 CC	+ 35°	50325	42100	34697	28116	22356	17419	13304	
	+ 45°	43601	36234	29689	23965	19064	14985	11728	
K 1500 CB	+ 35°	63624	53225	43865	35544	28263	22021	16818	
	+ 45°	55122	45808	37533	30298	24101	18944	14826	
K 2500 CC	+ 35°	63624	53225	43865	35544	28263	22021	16818	
	+ 45°	55122	45808	37533	30298	24101	18944	14826	
K 2500 CB	+ 35°	71405	59803	49351	40048	31895	24891	19036	
	+ 45°	61760	51384	42157	34079	27151	21373	16743	
K 3000 CC	+ 35°	71405	59803	49351	40048	31895	24891	19036	
	+ 45°	61760	51384	42157	34079	27151	21373	16743	
K 3000 CS	+ 35°	92541	78148	65072	53314	42872	33747	25938	
	+ 45°	80768	67725	55998	45589	36496	28721	22262	
K 3500 CC	+ 35°	92541	78148	65072	53314	42872	33747	25938	
	+ 45°	80768	67725	55998	45589	36496	28721	22262	
K 3000 CB	+ 35°	106062	89485	74421	60870	48832	38308	29298	
	+ 45°	92553	77572	64104	52149	41707	32779	25365	
K 4000 CC	+ 35°	106062	89485	74421	60870	48832	38308	29298	
	+ 45°	92553	77572	64104	52149	41707	32779	25365	
K 4500 CS	+ 35°	109990	92799	77177	63125	50642	39728	30384	
	+ 45°	95982	80446	66479	54082	43254	33995	26306	
K 4700 CS	+ 35°	121194	101309	83411	67500	53576	41639	31689	
	+ 45°	106053	87884	71701	57506	45297	35076	26841	
K 5000 CC	+ 35°	121194	101309	83411	67500	53576	41639	31689	
	+ 45°	106053	87884	71701	57506	45297	35076	26841	
K 5500 CC	+ 35°	130641	109854	91024	74149	59231	46268	35261	
	+ 45°	114598	95555	78468	63337	50161	38942	29678	
K 5000 CS	+ 35°	145311	121470	100010	80933	64238	49926	37995	
	+ 45°	127158	105373	85970	68950	54312	42056	32183	
K 6000 CC	+ 35°	145311	121470	100010	80933	64238	49926	37995	
	+ 45°	127158	105373	85970	68950	54312	42056	32183	
K 6000 CS	+ 35°	157452	131619	108368	87698	69610	54102	41176	
	+ 45°	137782	114179	93156	74715	58855	45576	34879	
K 7500 CC	+ 35°	157452	131619	108368	87698	69610	54102	41176	
	+ 45°	137782	114179	93156	74715	58855	45576	34879	

Temp. gas aspirato
Suction gas temperature
Temp. de gas aspiré
Sauggastemperatur

+ 25°C

- Nel caso di funzionamento a 60 Hz moltiplicare la resa per 1,18
- When operating at 60 Hz, multiply the capacity for 1,18
- Dans les cas de fonctionnement à 60 Hz multiplier le rendement par 1,18
- Falls Betrieb mit 60 Hz muss man die Leistung mit 1,18 multiplizieren

- Rese frigorifere senza sottoraffreddamento del liquido.
- Capacity rating without liquid subcooling.
- Puisseance frigorifique sans sous-refroidissement du liquide.
- Kälteleistungen ohne Flüssigkeitsunterkühlung.

1 Kcal./H = 1,163 W.
1 W. = 0,860 Kcal./h
1 W. = 3,412 BTU/h

UTILIZZARE SOLO P.O.E.
USE P.O.E. ONLY
UTILISER SEULEMENT P.O.E.
NUR P.O.E. ÖLE VERWENDEN

* = Vedere pagina
See pag
Voir page
Sehen sie Seite

7

- NON MISCELARE MAI OLII ESTERE
ESTERE
CON OLII DIVERSI
- NEVER MIX ESTER OILS WITH DIFFERENT OILS
- NE MÉLANGER JAMAIS ESTER HUILES AVEC DIFFERENT HUILES
- NIEMALS ESTERÖL MIT ANDEREN ÖLEN VERMISCHEN

TENTATIVE DATA



RESA FRIGORIFERA ED ASSORBIMENTO

PERFORMANCE DATA
Q = REFR. CAPACITY (WATT)

R404A/R507

DONNÉES DE PUISSANCE

LEISTUNGWERTE
P = POWER INPUT (KW)

Modello Model Modèle Modell	T. cond. Cond. temp. °C	Temperature Evapor. - Evaporating temperatur. °C - Temp. Evapor. - Verdampfungstemp.													
		Q	C						*	B				X	
			+10°	+5°	0°	-5°	-10°	-15°		-20°	-25°	-30°	-35°		-40°
K2500CB	+35°	W									35230	28065	22000	16890	12670
		kW									14,4	12,5	10,6	8,9	7,2
	+45°	W									29155	23000	17900	13600	10000
		kW									17,2	15	12,9	10,8	8,8
K3000CC	+35°	W	109610	92530	77670	64720	53480	43750		35360					
		kW	20,6	21,2	21,1	20,4	19,25	17,8		16,2					
	+45°	W	92680	78210	65550	54490	44860	36510		29300					
		kW	26,3	25,7	24,6	23,1	21,3	19,3		17,2					
K3000CS	+35°	W				77590	64420	53040		43200	34790	27630	21470	16425	
		kW				28,7	26,5	24,3		21,8	19,4	17	15	12,9	
	+45°	W				64675	53660	44080		35810	28700	22640	17500	13175	
		kW				31,9	29,2	26		23	20	17,4	14,8	12,4	
K3500CC	+35°	W	135850	114950	96730	80870	67110	55200		44920					
		kW	33,6	31,7	29,6	27,9	26	24,1		21,9					
	+45°	W	113470	96050	80820	67510	55920	45870		37200					
		kW	38,5	36,1	33,4	31	28,6	26		23,5					
K3000CB	+35°	W								50500	40670	32300	25100	19200	
		kW								25	22,2	19,5	17,2	14,8	
	+45°	W								41860	33550	26460	20460	15400	
		kW								26,2	23	20	17	14,2	
K4000CC	+35°	W	155620	131680	110810	92650	76880	63220		51460					
		kW	38,5	36,3	34	32	29,8	27,6		25,2					
	+45°	W	129990	110030	92590	77340	64060	52550		42620					
		kW	44,1	41,3	38,3	35,5	32,7	29,9		26,9					
K4500CS	+35°	W				99995	83020	68355		55675	44840	35610	27670	21170	
		kW				35,9	33,2	30,3		27,3	24,3	21,3	18,77	16,15	
	+45°	W				83350	69150	56810		46150	36990	29170	22560	16980	
		kW				39,9	36,47	32,5		28,7	25,1	21,8	18,6	15,5	
K4700CS	+35°	W				111090	92060	75640		61480	49370	39095	30445	23260	
		kW				38,6	36,1	32,9		29,4	25,9	22,5	19,3	16,4	
	+45°	W				90345	74630	61015		49290	39265	30770	23650	17760	
		kW				41,3	37,7	34		30,2	26,5	23,1	20,1	17,5	
K5000CC	+35°	W	190830	161150	135300	112830	93330	76470		61970					
		kW	40,6	40,9	39,75	37,6	34,9	31,8		28,55					
	+45°	W	160300	135100	113400	93820	77120	62680		50270					
		kW	50,9	48,7	45,7	42,1	38,2	34,3		30,5					
K5500CC	+35°	W	206090	174460	146930	122930	102060	83980		68360	54870	43450	33840	25850	
		kW	44,8	45,8	45,1	43,1	40,2	36,7		32,9	28,6	24,8	21,3	18,2	
	+45°	W	167340	141730	119320	99710	82600	67740		54880	43640	34195	26280	19740	
		kW	53,5	52	49,5	46,1	42,1	37,9		33,7	29,29	25,53	22,18	19,32	
K5000CS	+35°	W				136000	112700	92600		75260	60440	47860	37270	28470	
		kW				47,05	43,9	40		35,8	31,5	27,3	23,5	20	
	+45°	W				110600	91360	74965		60340	48065	37665	28950	21740	
		kW				50,3	46	41,4		36,7	32,3	28,1	24,4	21,3	
K6000CC	+35°	W	228850	193500	162750	135970	112710	92590		75300					
		kW	48,9	49,9	49,2	47	43,9	40		35,8					
	+45°	W	186960	158010	132710	110600	91360	74700		60340					
		kW	58,3	56,8	53,9	50,2	46	41,4		36,8					
K6000CS	+35°	W				148830	123330	101340		82360	66140	52380	40790	31160	
		kW				51	47,6	43,4		38,8	34,1	29,6	25,5	21,7	
	+45°	W				121035	99980	81740		66035	52600	41220	31680	23790	
		kW				54,5	49,8	44,8		39,8	35	30,5	26,5	23,1	
K7500CC	+35°	W	247960	209660	176340	147330	122120	100320		81560					
		kW	53	54,1	53,3	51	47,5	43,4		38,8					
	+45°	W	202570	171210	143790	119840	98990	80930		65380					
		kW	63,2	61,5	58,5	54,4	49,8	44,8		39,8					

Nel caso di funzionamento a 60 Hz moltiplicare la resa per 1,18
When operating at 60 Hz, multiply the capacity for 1,18
Dans les cas de fonctionnement à 60 Hz multiplier le rendement par 1,18
Falls Betrieb mit 60 Hz muss man die Leistung mit 1,18 multiplizieren

I motocompressori "CC" possono funzionare fino a -40° C d'evaporazione
Motocompressors "CC" can work up to -40° C evap. temp.
Les motocompresseurs "CC" peuvent travailler jusqu'à -40° C de température d'évaporation
Die "CC" verdichter können bis -40° C verdampfungstemperatur arbeiten



RESA FRIGORIFERA ED ASSORBIMENTO

PERFORMANCE DATA
Q = REFR. CAPACITY (WATT)

R407C

DONNÉES DE PUISSANCE

LEISTUNGWERTE
P = POWER INPUT (KW)

MODELLO MODEL MODELE MODELL	T.cond. Con. temp. T. de cond. Kon. temp. °C	Temperature Evapor.-Evaporating temper.-Temp. evapor.-Verdampfungstemp.°C							
		Q P	C		S			B	
			+ 10°	+ 5°	0°	- 5°	- 10°	- 15°	- 20°
K750CC	30°	W kW	39950 6,3	34330 6,2	29190 6,1	24510 5,9	20190 5,6	16280 5,3	12700 4,9
	40°	W kW	35720 7,7	30490 7,4	25810 7	21570 6,6	17640 6,2	14290 5,7	11020 5,1
	50°	W kW	31960 9	27240 8,5	22630 8	18750 7,4	15170 6,7	12030 6	9310 5,4
K1000CC	30°	W kW	50570 7,6	42770 7,5	35750 7,3	29430 7	23660 6,7	18730 6,2	14470 5,6
	40°	W kW	44140 9,1	37100 8,8	30700 8,4	25210 7,9	20210 7,4	16070 6,8	12230 6,1
	50°	W kW	38470 10,5	32120 10	26200 9,5	21300 8,8	16950 8,1	13270 7,3	10190 6,5
K1500CC	30°	W kW	61500 10,2	51980 9,9	43360 9,6	35560 9,1	28860 8,6	22800 8	17600 7,4
	40°	W kW	53540 11,9	44960 11,5	37240 10,9	30450 10,3	24610 9,6	19200 8,8	14770 7,9
	50°	W kW	45840 13,7	38160 13	31350 12,2	25440 11,3	20480 10,4	15770 9,3	11880 8,4
K2000CC	30°	W kW	75220 11,8	63580 11,3	53030 11	43500 10,6	35300 10,1	27890 9,4	21530 8,7
	40°	W kW	65480 13,9	54990 13,5	45550 12,9	37240 12,2	30100 11,4	23480 10,4	18060 9,4
	50°	W kW	56060 16,4	46680 15,7	38370 14,7	31120 13,6	25050 12,5	19290 11,2	14530 10,1
K2500CC	30°	W kW	95100 15,3	80380 15	67050 14,5	55000 13,9	44620 13,26	35250 12,4	27220 11,5
	40°	W kW	82800 18,4	69520 17,8	57580 16,9	47080 16	38050 14,9	29680 13,7	22830 12,3
	50°	W kW	70880 21,5	59010 20,5	48470 19,2	39350 17,9	31660 16,5	24380 14,8	18360 13,3
K3000CC	30°	W kW	109000 19,7	92130 18,9	76850 18,1	63030 17,2	51150 16,1	40410 15,1	31200 14
	40°	W kW	94890 22,6	79680 21,2	66000 20,3	53960 19	43620 17,6	34020 16,1	26170 14,6
	50°	W kW	81240 25,5	67630 24,1	55560 22,4	45100 20,7	36300 18,9	27951 17	21050 15,3
K3500CC	30°	W kW	141250 25,3	121150 24,9	101500 24,3	81830 23,4	67180 22,2	53070 20,8	40980 19,3
	40°	W kW	123690 30	105280 29,1	87430 27,8	70020 26,3	56940 24,6	44410 22,6	34160 20,4
	50°	W kW	106670 34,7	89900 33,2	73870 31,2	58490 29,1	47000 26,8	36190 24,1	27260 21,7
K4000CC	30°	W kW	162170 32,3	138970 31,3	116320 30,1	93690 28,6	76830 26,8	60700 25,1	46870 23,3
	40°	W kW	141910 37,3	120720 35,9	100190 33,8	80210 31,7	65190 29,4	50850 27	39100 24,4
	50°	W kW	120040 42,4	103050 40,2	84650 37,5	67030 34,6	53890 31,7	41500 28,5	31260 25,6
K5000CC	30°	W kW	196920 32,8	168800 32,4	141260 31,6	113740 30,4	93220 29	73640 27,2	56860 25,2
	40°	W kW	172630 38,5	146830 37,5	121830 35,8	97480 33,9	79160 31,3	61740 28,7	47500 25,9
	50°	W kW	149020 44,3	125540 42,4	103090 39,9	81590 31,1	65520 34,22	50450 30,7	38000 27,7
K5500CC	30°	W kW	216750 40,6	185710 39,3	155410 37,8	125130 36,1	102560 34,1	81020 32	62560 29,6
	40°	W kW	189930 47,1	161540 44,9	134030 42,2	107240 39,5	87100 36,5	67940 33,5	52260 30,2
	50°	W kW	163950 53,6	138110 50,3	113420 46,5	89760 42,6	72090 38,7	55510 34,8	41810 31,3
K6000CC	30°	W kW	236360 38,5	202510 38,7	169470 38,3	136450 37,5	111840 36,1	88350 33,9	68220 31,4
	40°	W kW	207110 47,6	176160 46,5	146160 44,5	116950 42,3	94980 39,6	74080 36,4	56990 32,8
	50°	W kW	178780 56,7	150610 54	123680 50,6	97880 46,8	78610 42,8	60530 38,5	45590 34,6
K7500CC	30°	W kW	256100 41,7	219420 41,9	183620 41,5	147850 40,6	121180 39,2	95730 36,8	73920 34,1
	40°	W kW	224400 51,6	190870 50,4	158360 48,3	126710 45,9	102910 42,9	80270 39,4	61750 35,6
	50°	W kW	193100 61,4	163190 58,6	134000 54,9	106050 50,7	85180 46,3	65590 41,6	49400 37,5

- Temp. gas aspirato
- Suction gas temperature
- Temp. de gas aspiré
- Sauggastemperatur

+25°C

- Rese frigorifere senza sottoraffreddamento del liquido.
- Capacity rating without liquid subcooling.
- Puissance frigorifique sans sous-refroidissement du liquide.
- Kälteleistungen ohne Flüssigkeitsunterkühlung

- UTILIZZARE SOLO P.O.E.
- USE P.O.E. ONLY
- UTILISER SEULEMENT P.O.E.
- NUR P.O.E. ÖLE VERWENDEN

32 cst

- Raffr. ausiliario o limitazione temp. asp.
- Additional cooling or limited suction gas temperature
- Refroidissement additionnel ou température du gaz aspiré réduite
- Zusatzkühlung oder eingeschränkte Sauggastemperatur

TENTATIVE DATA



CAPACITÀ FRIGORIFERA
REFRIGERATING CAPACITY

PUISSANCE FRIGORIFÈRE
KÄLTELEISTUNG

R22

Watt

MODELLO MODEL MODELE MODELL	Temp. cond. Cond. temp. Temp. de cond. Kond. temp. °C	Temperature Evapor. - Evaporating temp. - Temp. evapor. - Verdampfungstemp. °C										
		G		H		D		X				
		+10°	+5°	0°	-5°	-10°	-15°	* -20°	-25°	-30°	-35°	-40°
K 750 CC	+35°	30810	31874	32400	33188	33930	34628	35278	35880	36440	36960	37450
	+45°	33827	35183	35932	36832	37682	38482	39240	39960	40640	41280	41880
K 750 CS	+35°				30005	30247	30517	30804	31108	31428	31754	32086
	+45°				33077	33305	33548	33804	34072	34350	34638	34926
K 1000 CC	+35°	48181	50371	52158	53743	55228	56713	58198	59683	61168	62653	64138
	+45°	41300	44078	46247	48117	49884	51650	53417	55184	56950	58717	60484
K 1000 CS	+35°				33732	34188	34644	35100	35556	36012	36468	36924
	+45°				30305	30688	31072	31456	31840	32224	32608	32992
K 1500 CC	+35°	68091	72728	76905	80480	84055	87630	91205	94780	98355	101930	105505
	+45°	60040	64282	68487	72417	76165	79913	83661	87409	91157	94905	98653
K 1500 CS	+35°				41280	44411	47542	50673	53804	56935	60066	63197
	+45°				37008	39650	42292	44934	47576	50218	52860	55502
K 2000 CC	+35°	88680	93378	98177	102874	107572	112270	116968	121666	126364	131062	135760
	+45°	61213	67817	73407	78997	84587	90177	95767	101357	106947	112537	118127
K 2000 CS	+35°				52005	53688	55372	57056	58740	60424	62108	63792
	+45°				47332	49137	50942	52747	54552	56357	58162	59967
K 2500 CC	+35°	68077	73801	79525	84788	89800	94812	99824	104836	109848	114860	119872
	+45°	77388	83210	89032	94854	100676	106498	112320	118142	123964	129786	135608
K 2500 CS	+35°				61347	64184	67021	69858	72695	75532	78369	81206
	+45°				55114	58571	62028	65485	68942	72399	75856	79313
K 3000 CC	+35°	88348	94280	100212	106144	112076	118008	123940	129872	135804	141736	147668
	+45°	68701	75009	81317	87625	93933	100241	106549	112857	119165	125473	131781
K 3000 CS	+35°				77940	84701	91462	98223	104984	111745	118506	125267
	+45°				68453	73276	78100	82924	87748	92572	97396	102220
K 3500 CC	+35°	130421	142018	153615	165212	176809	188406	199993	211590	223187	234784	246381
	+45°	117188	126808	136428	146048	155668	165288	174908	184528	194148	203768	213388
K 3000 CS	+35°				48810	50077	51344	52611	53878	55145	56412	57679
	+45°				41520	43017	44514	46011	47508	49005	50502	52000
K 4000 CC	+35°	148670	159182	170694	182206	193718	205230	216742	228254	239766	251278	262790
	+45°	134418	145218	156018	166818	177618	188418	199218	210018	220818	231618	242418
K 4500 CS	+35°				60410	62884	65358	67832	70306	72780	75254	77728
	+45°				57909	57777	57644	57511	57378	57245	57112	56979
K 4700 CS	+35°				118805	123813	128821	133829	138837	143845	148853	153861
	+45°				69214	71883	74552	77221	79890	82559	85228	87897
K 5000 CC	+35°	181888	196667	211446	226225	241004	255783	270562	285341	300120	314899	329678
	+45°	163098	179339	195580	211821	228062	244303	260544	276785	293026	309267	325508
K 5000 CS	+35°				136338	142811	149284	155757	162230	168703	175176	181649
	+45°				118001	124000	130000	136000	142000	148000	154000	160000
K 6000 CC	+35°	218877	236823	254769	272715	290661	308607	326553	344499	362445	380391	398337
	+45°	198919	218248	237577	256906	276235	295564	314893	334222	353551	372880	392209
K 6000 CS	+35°				148888	157980	167072	176164	185256	194348	203440	212532
	+45°				138871	146084	153297	160510	167723	174936	182149	189362
K 7500 CC	+35°	238839	264047	289255	314463	339671	364879	390087	415295	440503	465711	490919
	+45°	212715	239207	265700	292192	318685	345177	371670	398162	424655	451147	477640

Temp. gas aspirato
Suction gas temperature
Temp. de gas aspiré
Sauggastemperatur
} + 25°C

Rese frigorifere senza sottoraffreddamento del liquido.
Capacity rating without liquid subcooling.
Puissance frigorifique sans sous-refroidissement du liquide.
Kälteleistungen ohne Flüssigkeitsunterkühlung.

★ = Vedere pagina
See page
Voir page
Sehen sie Seite
} 6

1 Kcal./h = 1,163 W.
1 W. = 0,860 Kcal./h
1 W. = 3,412 BTU/h

Nel caso di funzionamento a 60 Hz moltiplicare la resa per 1,18
When operating at 60 Hz, multiply the capacity for 1,18
Dans les cas de fonctionnement à 60 Hz multiplier le rendement par 1,18
Falls Betrieb mit 60 Hz muss man die Leistung mit 1,18 multiplizieren

I motocompressori "CC" possono funzionare fino a -40° C d'evaporazione
Motocompressors "CC" can work up to -40° C evap. temp.
Les motocompresseurs "CC" peuvent travailler jusqu'à -40° C de température d'évaporation
Die "CC" verdichter können bis -40° C verdampfungstemperatur arbeiten